



**ULYSSE**  
CAMERACRANEBOT

**MEET THE  
CAMERA CRANEBOT**

[ulyссе.tv](http://ulyссе.tv)

# Meet the Camera Cranebot

## Features

Reimagine motion control with the world's first camera cranebot.

Operate Ulysse intuitively to make your work ideas **easier, faster and safer.**

Operate & interact **in real time** with joysticks & 3D sensors.

**Sync FIZ drives** with HS LENS DRIVE and/or your favorite 7 PIN DIGITAL LENS DRIVE.

**Play and Repeat** from stop motion to High Speed.

**Freedom of movement.** 4,30m of horizontal range and a 3,50 m height.

Compatibility with **all cameras**, up to 40kg of load.





# Motion control reinvented

---

## Experiment organic Motion Control

Operate in real time thanks to joysticks & 3D sensors. Ulysse movements will flow with your creativity.

---

## Precision and interactivity open to inspiration

Easy Setup, Smart Programming, wide camera movements range. Shooting your ideas becomes faster and easier.

# Technical Specifications

---

## MAX PAYLOAD

40 kg

## POINT PRECISION

+/- 0,06 mm

## REPEATABILITY

+/- 0,28 mm

## MAX REACH

2,55 m

## MAX VERTICAL HEIGHT

3,50 m

## MAX HORIZONTAL

4,30 m

## SPEED

FROM STOP MOTION TO  
HIGH SPEED  
(DRAGONFRAME  
COMPATIBLE)

## MAX SPEED

4 m/s

## WEIGHT

850 kg

[without suspension struts]

950 KG [with suspension struts]

## CRANEBOT CONTROLLER WEIGHT

150 kg

## CONTROLLERS

---

JOYSTICKS PANEL

EMBEDDED 3D MOUSE

3D SENSOR [HTC VIVE]

CRANEBOT USER INTERFACE

CRANEBOT FLEX REMOTE

## POWER REQUIREMENTS

---

3 x 400 VOLTS

25 A (63 A P17 PLUG)

50-60 HZ

## ULYSSE BREAK-OUT-BOX

---

1 x 110 -220 V POWER IN

2 x 24 V OUT (XLR3)

2 x 12 V OUT (XLR4)

4 x RJ45 - GIGABIT

1 x BNC HD-SDI IN

3 x BNC HD-SDI OUT

1 x BNC Timecode

3 x LENS DRIVE FIZ

1 x BNC GENLOCK

8 x TRIGGER RELAY

# Reel Time Controllers

---

## EMBEDDED SPACE CTRL



Move in Real time  
with 3 fingers

## REMOTE CONTROL



Move in Real Time, Play  
& more functions

## 3D SENSOR



Operate in real time with  
your favorite camera head

## HTC VIVE COMPATIBLE



Draw your camera  
trajectories

## XBOX COMPATIBLE



Use an Xbox gamepad

# Safety Box

---



- 6 OUTPUT TRIGGERS
- CAMERA REC/STOP
- 2 DIGITAL Inputs



Safety enabling Devices

# FIZ

---



High Speed lens Drive



Compatible with 7 pins lens drive

# METIS MOVE CREATOR

---



EDIT, PLAY & RECORD with an easy and intuitive interface

# Working Range

2,55 m / 8,37 ft

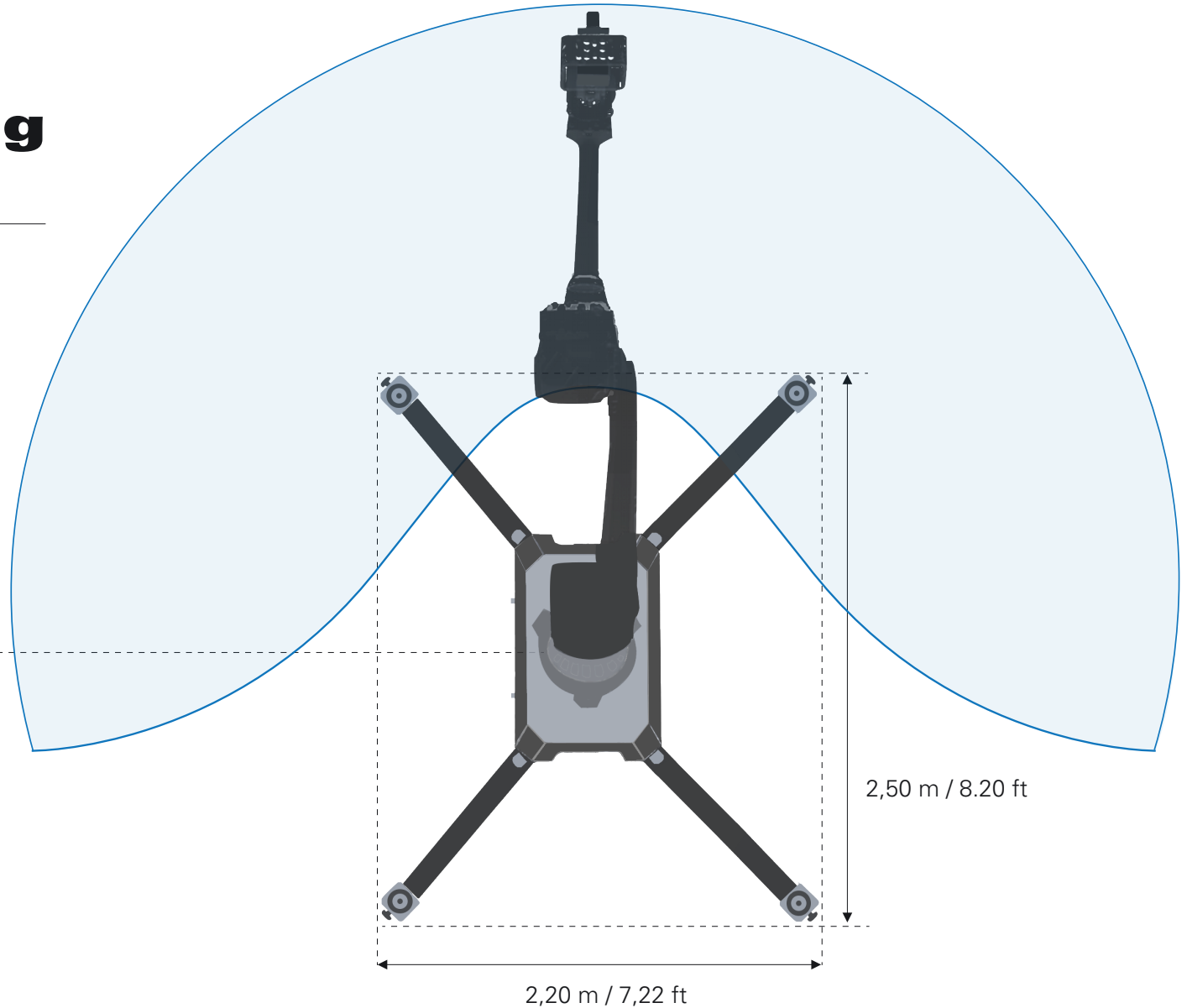

# Working Range

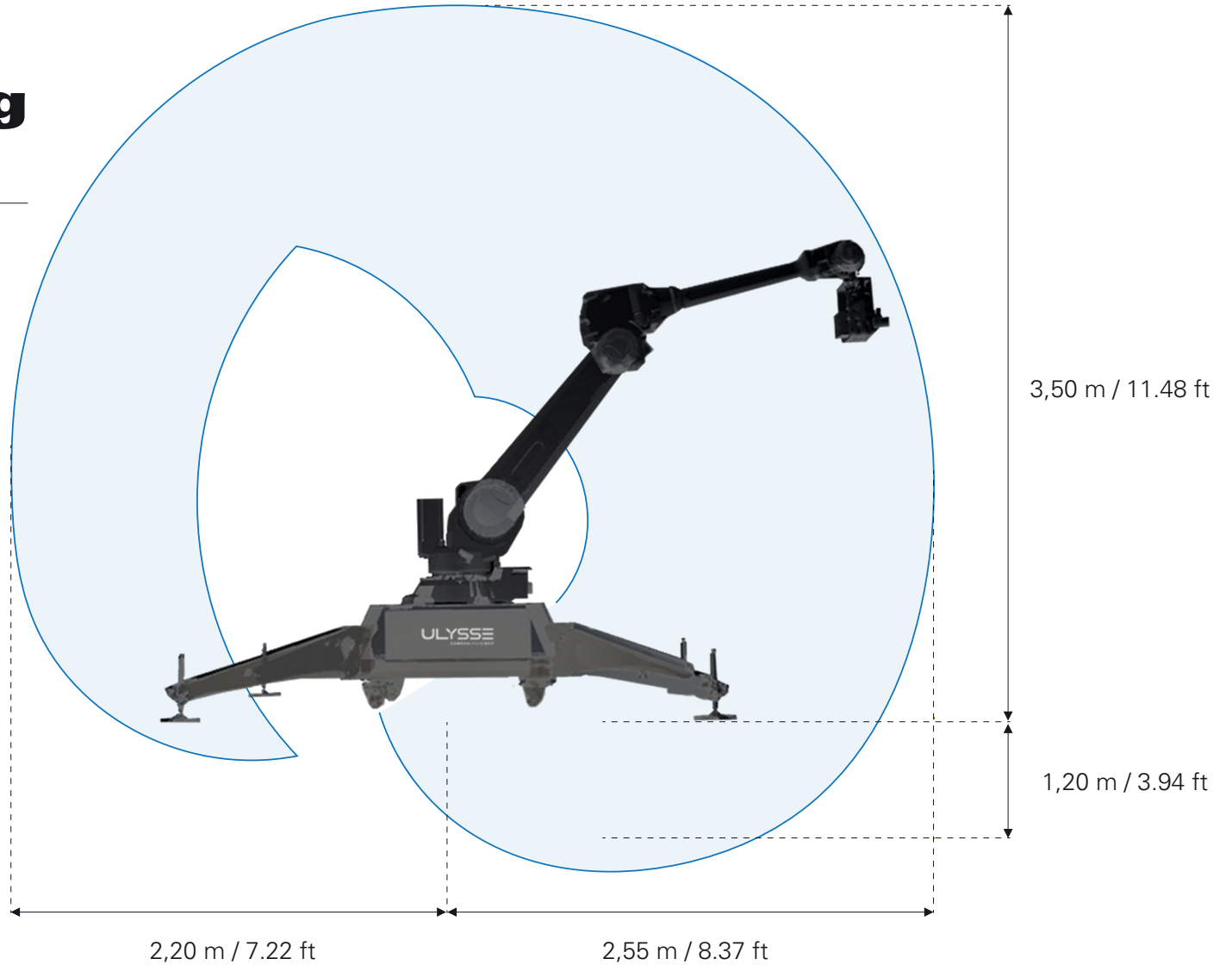



# Transport Size

---

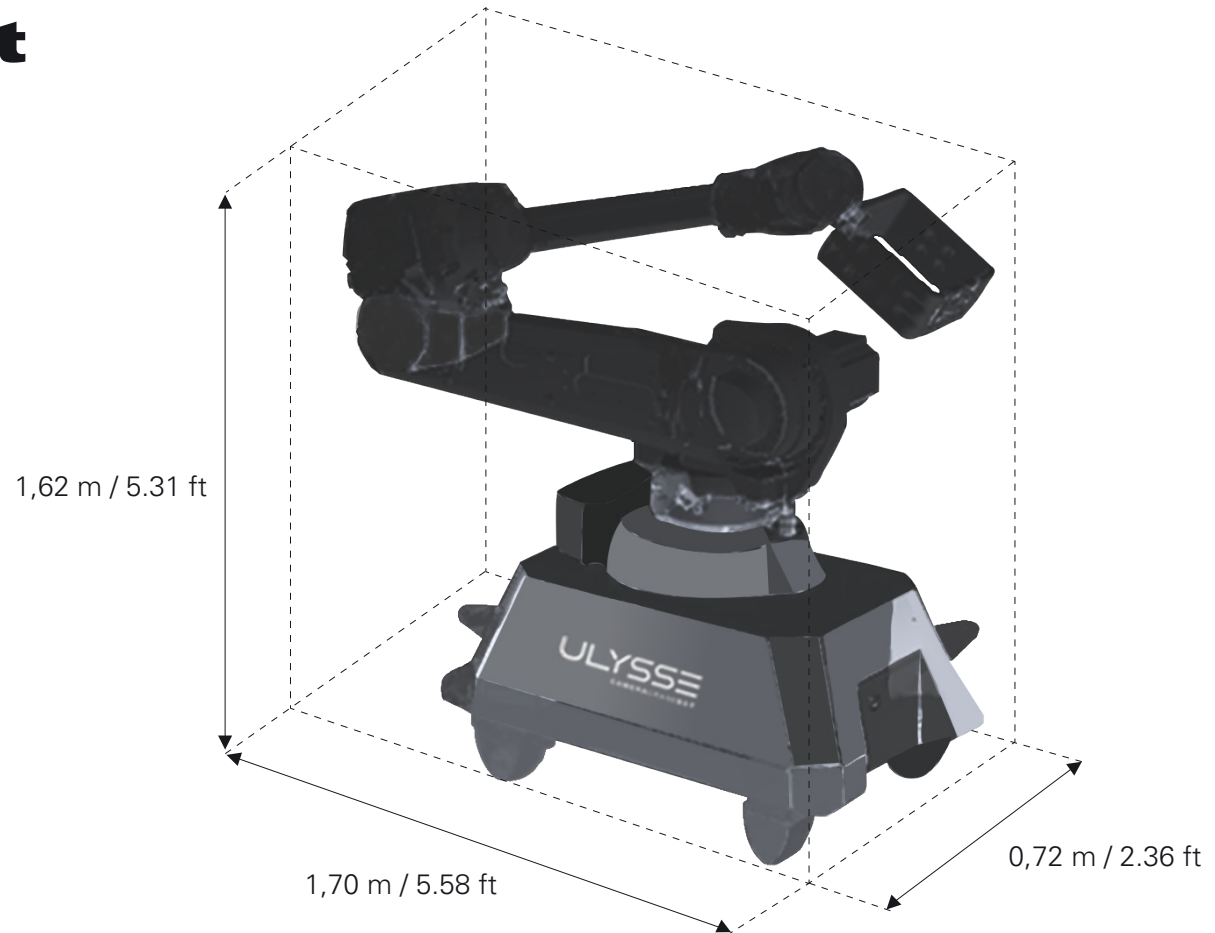

# Why Ulysse?

---

## A game changing solution

Because you take your job very seriously. We are on a mission to make motion control more agile and inspiring so you can make the most of your ideas.

## By professionals for professionals

---

Ulysse has been designed by professional directors of photography to let you focus on what you do best: experimenting, playing and finding solutions. Bring Ulysse to any location, as it fits in a van and can go through a regular door... and start working in minutes.

## Motion control as it should be

---

In this creative challenge we have ditched eternal set-ups, included fully interactive and intuitive controls all while allowing you a 4,30 m horizontal travelling without without tracks.

## A happier and more challenging workflow

---

Live record your movements with joysticks or 3D sensors. Accelerate, decelerate, edit, repeat, tweak and repeat them again through the intuitive interface. Fast, accurate and flexible, Ulysse is your ready to go solution for control motions in filmmaking, advertising, media or art.

## A business lifetime solution

---

Count on us for training, help and inspiration. In addition, our software will be always up to date through our license system, where we'll offer you bespoke control solutions to let your ideas flow.



# Ulysse in a few testimonies

---

For a CHANEL commercial project, I was looking for a big range and an extremely accurate motion control. From Micro POV to wide angle, Ulysse Camera Cranebot met all my expectations and more. Result: a real technical success. Ulysse is so easy to operate and to set up. This motion control will be essential on the next projects.

---

**Patrick Duroux AFC**  
DOP

Ulysse is the renew of the motion control, a real increased machinery allows a new camera angle's approach. Its motion controllers and its software allow an accurate and a quick setting up of the trajectory. Ulysse gives a great artistic freedom I never felt before.

---

**Olivier Labois**  
ULYSSE OPERATOR

I wanted a motion control capable of doing complex movements. I was looking for intuitiveness, interactivity and easy to use. It is for these reasons I created Ulysse Camera Cranebot, which allows me to focus on my work and make my ideas reality. Ulysse do not change our way of working, just it increases our creativity and our pleasure to create.

---

**Raoul Rodriguez**  
Sublab CEO, DOP

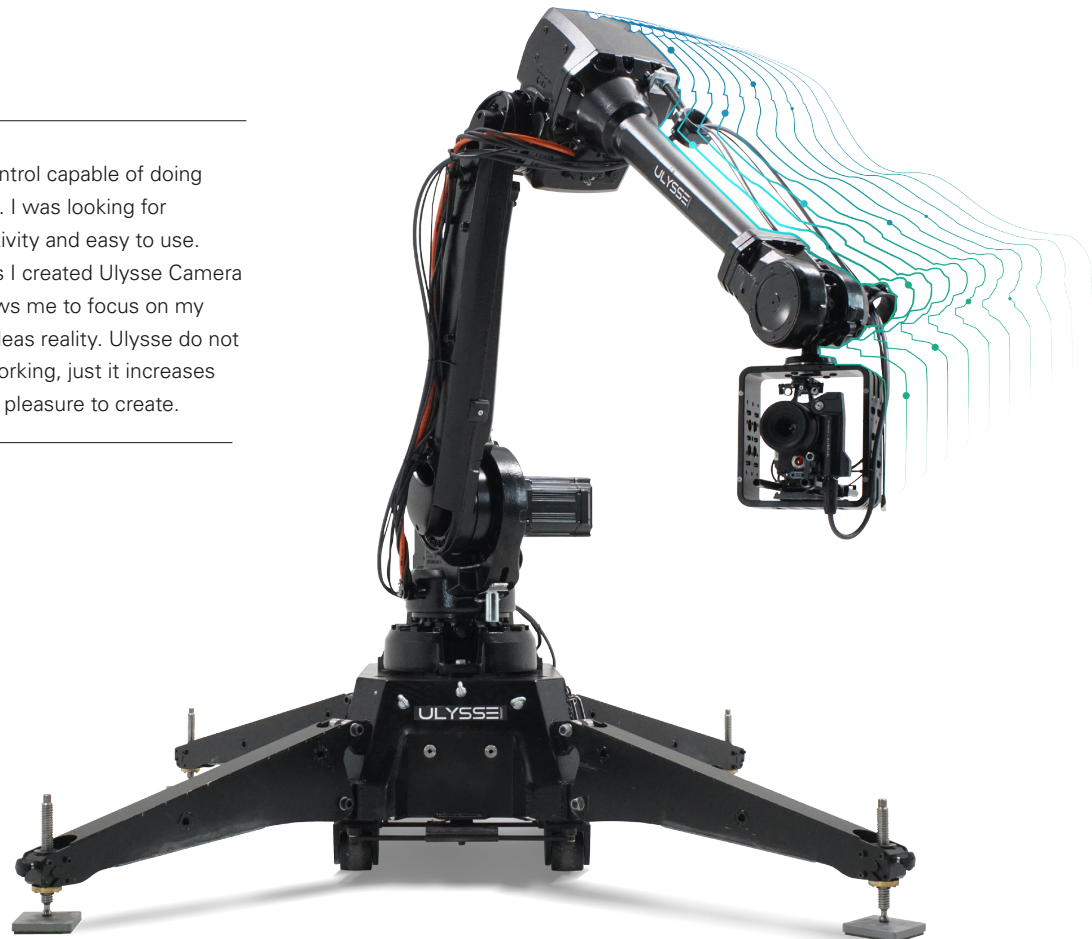

**ULYSSE**  
CAMERACRANEBOT

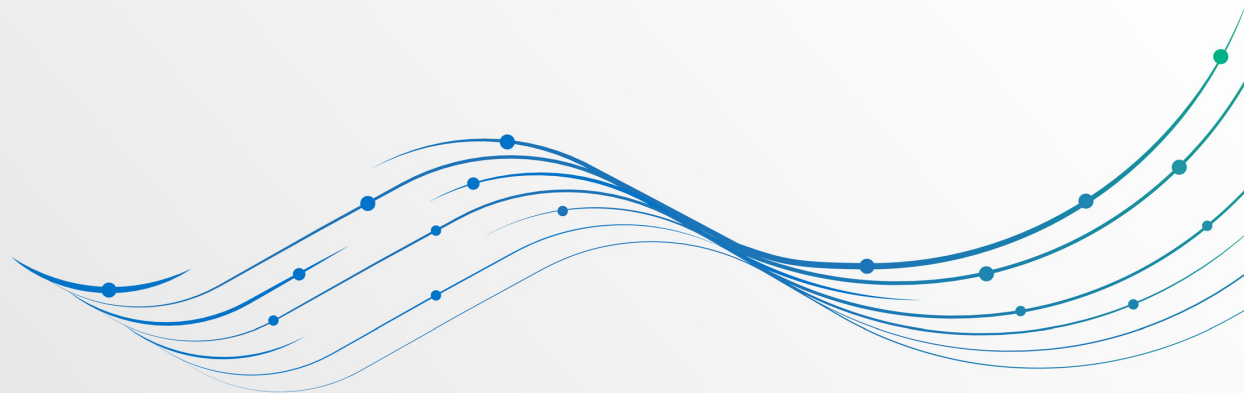

info@ulyse.tv  
+33 981 02 93 96  
**ulyse.tv**

Ulyse is a product by:

**sublab**